



OPERATION AND CARE GUIDE

THIS GUIDE IS INTENDED TO SUPPLY YOU WITH THE INFORMATION TO GET THE MOST FROM YOUR FLOAT POD. WITH PROPER CARE AND REGULAR MAINTENANCE, YOUR FLOAT POD WILL PROVIDE YOU WITH YEARS OF TROUBLE FREE RELAXATION, HYDROTHERAPY AND ENJOYMENT.

FLOAT POD PRE-SITE PREPARATION

Installation Considerations:

It is highly recommended that the owner/user of this Float Pod carefully read all instructions in this manual prior to having your Float Pod installed at your chosen location. **IMPROPER INSTALLATION MAY RESULT IN EQUIPMENT DAMAGE AND VOID THE FLOAT POD'S WARRANTY.**

GETTING THE FLOAT POD TO YOUR SITE

- All portable Float Pods come in three main sections. The largest section requires clearance for a 32X68X103 inches object through gates, doors, between houses and side fences, around corners and at least 9 feet of overhead clearance for ample moving room. It is the customer's responsibility to make sure all clearance requirements are met.
- We deliver to your door step and do not offer installation and setup. If your drop off spot is not fully prepared, there will be an additional charge for the second delivery. Customer pays for the crane service and/or any additional manpower needed. It is the customer's responsibility to remove and replace all obstacles that may impede proper installation and setup.

FLOAT POD PAD REQUIREMENTS

Your new Float Pod **MUST BE PLACED ON A UNIFORMLY FIRM AND LEVEL SURFACE.** The pad foundation recommended is a concrete pad at least 4 inches thick. Refer to your brochure for foundation/pad size requirements. You will need at least 2 feet of space being the Float Pod to access electronic components. If a concrete pad is poured, this is the logical time to "plumb-in" your electrical conduit for 220 volt power line if desired. Be sure the concrete has cured for at least one week before setting the Float Pod in place. A typical Float Pod, once filled with water, could weigh as much as 3,600 lbs. **AN UNEVEN OR CRACKED CONCRETE PAD, OR IMPROPERLY SHIMMING YOUR FLOAT POD MAY CAUSE THE FLOAT POD TO BUCKLE, DISTORT AND / OR CRACK, RESULTING IN THE VOIDING OF YOUR FLOAT POD'S WARRANTY.**

ADDITIONAL REQUIREMENTS

- All installations require the equipment system to be shielded from the weather. If the equipment system is placed away from the Float Pod then an enclosure will need to be built over it. The customer is responsible for providing this enclosure. Float Pods delivered without their cabinet structure, (not *skirted*) will need additional requirements to prevent environmental damage.
- Balconies and decks must be constructed to current state and local codes to safely support the maximum load of your water filled Float Pod. Check with your construction contractor for these specifications. Balconies and decks should support at least 80 pounds per square foot.
- It is the responsibility of the owner to provide clear access on **all sides** of the Float Pod in the event a repair is necessary. Otherwise, additional costs to the customer for the service and repair of the Float Pod may be incurred.
- It is not recommended to backfill against the Float Pods shell or cabinet. This will damage the Float Pod and void your warranty.
- During colder months: You will need to fill the Float Pod with a hose with a water source. ***The Delivery Carrier does not bring a hose or water.***

ELECTRICAL REQUIREMENTS

**220 Volt
30 Amp.-
(4 Wires Total)**

Most 220 volt, 4.0 KW Equipment Systems requires two #6 gauge wires plus a ground wire and a neutral (**4 wires total**). A 30 Amp. Double Pole GFCI Breaker should be directly hard-wired to the breaker panel. (Copper Wire Only) A Disconnect Box is required within eyesight and 2.5 feet from the ground **or more**. The GFCI may be located in the Main Breaker box or in the Disconnect Box. **IF THE WIRE IS TOO SHORT, ROYAL SPA WILL NOT BE ABLE TO HOOK-UP YOUR FLOAT POD. THE FLOAT POD COMES WITH A 5 FOOT 4 PRONG PLUG AND SPECIAL NEEDS NEED TO BE COMMUNICATED BEFORE SHIPMENT. ROYAL SPA IS NOT A LICENSED ELECTRICAL CONTRACTOR AND CANNOT RUN EXTRA WIRE.**

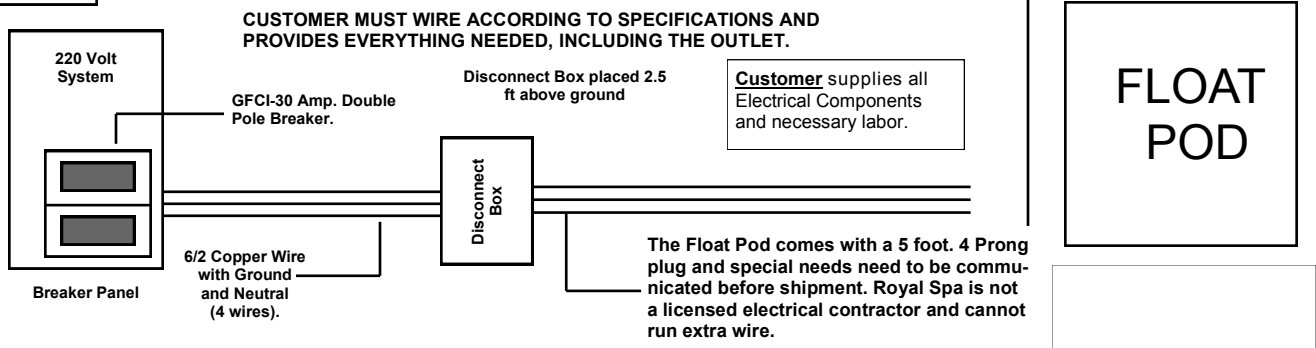

THE FLOAT POD COMES WITH A 5 FOOT 4 PRONG PLUG AND SPECIAL NEEDS NEED TO BE COMMUNICATED BEFORE SHIPMENT.



NO EXTENTION CORDS are to be used in conjunction with the operation of the Float Pod. Low voltage damage could result which is not covered by warranty. All electrical work must be done according to NEC (National Electric Code) and any other applicable electrical codes.

Electrical Stub-Up Locations

For Portable Float Pods

With Their Standard Equipment Location

****Measurements Are For Commercial Float Pods**

Models:
Float Pod

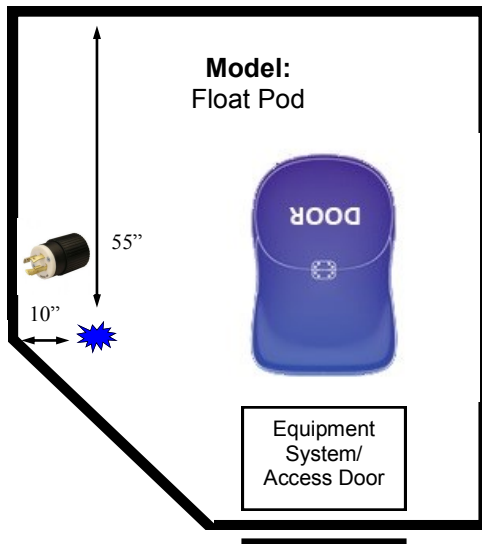
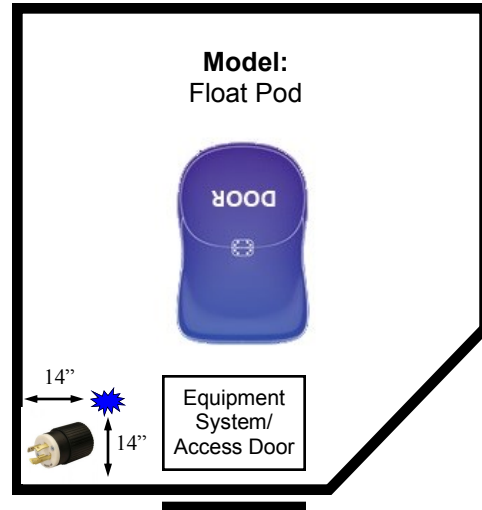
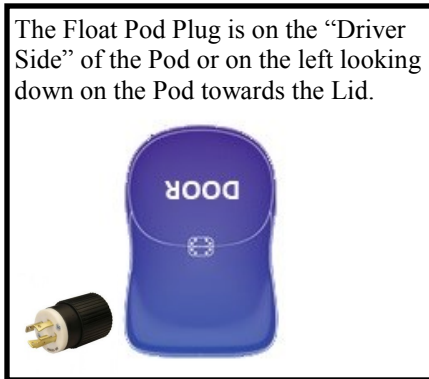

In the case of an odd room layout you will need to request a custom length Float Pod Plug.

For wiring a “**Float Pod**”, start at the corner immediately to the left of the Access Door. From that left corner go to the left edge of the Float Pod. Measure 2.5 to 4 feet off the ground toward the corner parallel to the Access Panel. This location is the best stub-up location for your electrical connection.

This form refers specifically to Float Pods in their standard equipment locations. Customizing the location of your equipment system or the design of the Float Pod may change the location dimension outlined on this form.

IMPORTANT SAFETY INSTRUCTIONS

READ AND FOLLOW ALL INSTRUCTIONS CAREFULLY

Clearly understand the specifics of safe operation and proper maintenance of your Float Pod. Float Pods are fun; but along with the fun comes serious responsibility. Establish rules and enforce them. It is your responsibility to be sure that you, your family and guests use the Float Pod safely.

INSTALLATION SAFETY NOTES

WARNING: Turning the Float Pod equipment switch **off** does not prevent risk of shock. Power in the equipment area is still live until the main breaker is shut off

WIRING: Wiring must be done by a licensed electrical contractor. Spa must be installed with a GFI (ground fault interrupter) in the breaker panel and dedicated to the Float Pod only. Wiring must meet the requirements of National Electric Code, ANSI/NFPA70-1999 and any other applicable state and local codes.

ELECTRICAL SHOCK: Never allow any electrical appliance or device within reach (5' to 10') of Float Pod. Electrical appliances include, but not limited to lighting, radio, TV, yard tools, extension cords or any plug-in devices.

EQUIPMENT MAINTENANCE: Never perform any work on the Float Pod equipment or electrical components without first turning off the main **Float Pod breaker** in your. It is recommended that a qualified Royal Spa Service Tech do any spa equipment repairs. Any problems with Breakers, GFI, main wire or disconnect should be serviced by a licensed electrician.

FLOAT POD BASE: The Floor base must be designed to hold the weight of the spa, water, and occupants. **Base** must be level and designed to prevent settling. **Base** must meet any applicable local and state codes.

MAINTENANCE SAFETY NOTES

REPAIRS: Always contact Royal Spa Service and Repair Department before attempting electrical or mechanical maintenance / repairs.

FILTERS: Always turn Float Pod off when removing skimmer or filter for cleaning, reinstall and turn power back on when cleaning is complete.

WATER BALANCE: Proper water balance must be maintained to prevent damage to the Float Pod and equipment, and to keep the water a comfortable neutral environment.

BACTERIA: Proper use of sanitizers after Float Pod use and at weekly intervals is recommended to maintain safe and bacteria free Float Pod water.

CHEMICAL LEVELS: Excessive chemical levels or the lack of chemicals continue to be the main cause of Float Pod damage, strong and unpleasant odor, and floater discomfort.

CHEMICAL HANDLING: Always use caution when handling chemicals. Spa chemicals are **concentrated**, poisonous if swallowed or inhaled, corrosive to the touch and can cause burns to the skin and eyes. It is recommended to wear eye protection when working with chemicals and immediately rinse off any chemical that comes in contact with your skin.

CHEMICAL STORAGE: Always store chemicals out of the reach of children. Make all family members aware of the chemicals potential dangers. Store chemicals in a dry, cool, safe place. NEVER mix chemicals together! REMEMBER, chemicals are made to be put into water. NEVER add water to the chemicals.

FLOAT POD USE SAFETY NOTES

FLOAT POD LID: The Float Pod lid has been designed for an easy exit. Simply push up on the lid and the hydraulic arms will open the lid. Should the lid become harder to open please contact a representative.

FLOAT POD USE SAFETY NOTES

HYPERTHERMIA: Hyperthermia occurs when the body's internal temperature increases a few degrees above normal body temperature of 98.6°F (37°C). The symptoms include lethargy, drowsiness, dizziness, and fainting. **PREVENTION**– The Float Pod should optimally be operated at 93.5°F. Do not exceed 95°F.

SICKNESS: It is not recommended that any person enter a Float Pod with open wounds, sores, viral or infectious diseases.

SUCTION FITTINGS: Two skimmer units in the Float Pod are designed to pull in water at a safe suction/flow rate. Do not stick hair, fingers or any other body part into these skimmers. If any of these suction skimmers break or crack, discontinue use and call Royal Spa Service for repair.

MEDICATION: Soaking in hot water may intensify or exaggerate the effects of many medications. You should contact your physician for his recommendations prior to Float Pod use.

ALCOHOL OR DRUGS: Soaking in hot water will intensify or exaggerate the effects of alcohol and most drugs. The use of alcohol or drugs could make one unable to get out of the Float Pod or cause unconsciousness and drowning. It is recommended that you avoid consuming alcohol or drugs before or while using a Float Pod.

TIME LIMITS: Always observe a reasonable time limit and temperature while using your Float Pod. Remind family and guests of these limits.

WATER TEMPERATURE: The Float Pod should optimally be operated at 93.5°F. Temperatures should not exceed 95°F (35°C). People with any health condition, including pregnancy, should consult their physician prior to use.

SALT CONTENT: The Float Pod should be kept at an ideal salinity level of 1.26 to 1.3 specific gravity. This can be measured with a hydrometer. In order to maintain this range it is recommended that Magnesium Sulfate or Epsom Salt be added daily or weekly. In the US it is recommended that a USP Grade of Epsom Salt be used for the Float Pod. The Float Pod requires approximately 6lbs of Salt per Gallon of water.

CPR: It is a good idea to have at least one responsible person who is trained in artificial respiration and/or cardiopulmonary resuscitation (CPR).

CHILDREN'S SAFETY AND YOUR FLOAT POD

ACCIDENTAL DROWNING: Extreme caution must be exercised to prevent unauthorized use or access to the Float Pod by unsupervised children. The Float Pod lid must remain closed when not in use.

CHILD ACCESS: Never allow a child to stand or play on or around the Float Pod..

CONDUCT: There should be no playing, wrestling or rough-housing in, on or around the Float Pod. Never allow children to walk around the Float Pod, jump or dive into the Float Pod.

RESPONSIBILITY

The responsibility of proper maintenance, conduct, use, and above all safety is all in your hands as a Float Pod owner. The responsibility of informing your guests and their children of Float Pod rules and safety concerns is also your responsibility and a very important prevention tool.

USING CHEMICALS

The chemicals needed for your Float Pod help make it clean, disinfected and more attractive to use. But remember, these chemicals are potentially dangerous and may present some hazards if not used properly. Carefully follow the manufacturer's instructions for the use and storage of chemicals.

In general, here are some tips for chemical usage and storage: Before using chemicals, read the labels and directions carefully. Follow label use instructions.

Keep all chemicals out of the reach of children.

Storage & Usage of Your Float Pod Chemicals

- Chemicals for test kits should be replaced every year.
- Keep the original lids on all chemical containers and make sure the lids are closed tightly when not in use.
- Do not stack different chemicals on top of one another.
- Store your Float Pod chemicals in a clean, cool, dry and well ventilated area preferably off the floor to prevent contamination from other materials. Keep them away from chemicals and equipment used for garden and lawn maintenance.
- Do not store your Float Pod chemicals where other flammable items may mix with them. For example, a mixture of these chemicals and fertilizer can cause a fire or explosion.
- Keep liquid chemicals away from dry chemicals. Keep apart chemicals which are different forms of oxidizing compounds. Physically separate all different forms of chemicals.
- Do not inhale dust or fumes from any chemicals. If necessary, use proper protective devices for breathing, handling and eye protection. Promptly wash off any chemical residues which get on your skin.
- Never reuse old chemical containers unless specified by the manufacturer.
- If you have any questions regarding safe handling, storage or use of Float Pod chemicals, contact the manufacturers.
- Wash out empty disinfectant containers before disposing to eliminate danger of fire, explosion or poisoning
- Carefully clean up any spilled chemicals with large amounts of water, to dilute and wash away the chemicals. Disinfectants and pH adjustment chemicals can usually be sent to the sewer with large quantities of water, since they are intended for use at low levels.

USING CHEMICALS

Storage & Usage of Your Float Pod Chemicals (Continued...)

- Always add the chemicals directly to the Float Pod, either in a suitable feeder, distributed across the surface of the water or diluted and poured into the water. Always add chemicals to water. Never add water to chemicals. Follow label use instructions.
- When preparing water solutions for feeder application, pour the chemical slowly into the appropriate amount of water, stirring constantly to provide mixing and dilutions.
- Never add chemicals to the Float Pod water while people are using the facility/spa.
- Test the water in your Float Pod with a reliable test kit on a schedule. Add the necessary chemicals according to the test results and the manufacturer's instructions. In the hot water environments of Float Pods, disinfectants may rapidly break up and spread out, requiring more frequent water testing. Follow your manufacturer's instructions in this regard. The more people who use the facility/pod, the more frequently you should test the water.

- **Notes:** You must come up with your own schedule, but in general we recommend a weekly chlorine shock (do NOT use granules, but instead use diluted liquid). Wait 24 hours before resuming use. Check residual levels are safe to resume using the Float Pod.
- Spa Enzymes and Clarifiers break down body oils, lotions and other substances entering the Float Pod from the skin or hair of floaters.
- The Float Pod filters 24/7 when not in use and Ozone and UV are constantly in operation.

INITIAL INSTALL AND START UP

1. Put top of Float Pod securely onto base. Insert bolts and tighten accordingly.
2. Put door hinge on. Make sure pull bolt is all the way through. Check hinge screws are tight.
3. Caulk inside of pod, where top and base meet, with white 100% silicon. This keeps moisture out and also finished the look of the Float Pod. **Let silicon set and wait at least 3 hours before continuing to the next step.**
4. Make sure Pod is NOT plugged into wall disconnect box. Plug in and/or wire low voltage equipment. (3 wire Intercom, 3.5mm Lobby Audio, RJ45 plug for Lobby control or WIFI adapter)
5. Fill tub area with 900lbs of Epsom Salt.
6. Begin adding hot water from a garden hose.
7. Getting into the Pod with a bucket and adding salt to the bucket will help the process. Keep adding salt to the bucket and keep hot water running into the bucket. Begin agitating Salt.

NOTE: Filling with water through the Skimmer Basket can help prevent an airlock in your circulating pump. Begin doing this once water is approaching fill line.

8. Once your water meets the fill line, stop filling with water. (About 3/4 the way up on the surface skimmer.)
9. Plug Pod in and turn power on at your Disconnect Box.
10. Turn thermostat(s) **OFF** - at Equipment System in cabinet.
11. Be sure **ON/OFF** switch is **ON** at Equipment System in cabinet.
12. Check to be sure the Circulating Pump is operating (water flowing from small jets in foot-well). One jet may be the Ozonator Jet and not appear to be working. You can also check the tube coming out of the small Circulating Pump, (at Equipment System inside of the cabinet) and going into the Heater Housing, to see if the water is flowing properly.
13. Run jets for 2-3 minutes with the heat still in the **OFF** position.

INITIAL INSTALL AND START UP cont...

14. Check to be sure there are no air locks:
 - a. Filter (loosen Bleeder Valve on top of filter until water runs out)
 - b. Circulating Pump
*(**WARNING** Air locks can cause instantaneous heater failure, known as “dry firing”, and this is **not** covered under warranty)*
15. Check for water leaks at Couplers on Pumps-hand tighten if necessary.
16. Turn thermostat(s) **OFF** - at Equipment System in cabinet.
17. Periodically check temperature of water to until desired temperature is reached.
Reduce thermostat setting until **HEAT** light turns off.
18. Add initial chemicals according to the “Refilling Your Float Pod” section of this manual.
19. Do Timely Maintenance as directed, and **ENJOY YOUR FLOAT SPA!**
20. Contact your local Royal Spa Representative to answer any questions that you may have.

WATER MAINTENANCE

Every Float Pod is Different: Important Chemistry Information

Every pod is different and maintaining a proper water chemical balance is not an exact art. Different pods will require different maintenance intervals and chemical amounts. Water balance is maintained within a safe range that is friendly to both pod and the spas bathers/occupants.

Many factors effect the maintenance, chemical amount, and frequency of chemical balancing of a pod. Factors that greatly effect pod maintenance and chemicals include: pod size or gallons, source and quality of water, environment around pod, what is tracked into pod water, cleanliness of bathers, number of bathers, frequency of use, temperature of water, drain and refill intervals, and overall quality of maintenance.

The chemical and water balancing information provided in this book is designed to give our customers a base line or starting point. The information may not be perfect or exact for your application but will help give you a good starting point and general idea of what needs to be done to properly maintain your spa. Any of the information can be modified or fine tuned by a qualified Royal Spa professional to match your particular Float Pod needs.

In many areas of the country, the pH & Total Alkalinity is very HIGH.

How To Bring Your pH & Alkalinity Down:

1. Add 1 ounce of pH/Alkalinity Down per 100 gallons of spa water (500 gal. = 5 oz.) and run the jets to mix and dissolve for several minutes.
2. (Approximately 15 minutes later) Re-check the spa water and if either the pH or Alkalinity is still High, add 1/2 ounce of pH/Alkalinity Down per 100 gallons of spa water (500 gal. = 2 to 2.5 oz.) and run the jets to mix and dissolve for several minutes.
3. Repeat step (2) until both the pH and Alkalinity are within the ideal ranges of your testing kit.
4. Re-check the spa two days later and adjust again if needed.
5. Do not add pH Up and pH Down in the same day. This will help avoid pH Bounce.
6. Log the number of ounces used to balance your hot tub water as you balance it the first time so that in the future you can add that amount all at once at time of fill up to achieve balanced water much quicker. (For Example: If it takes 10 ounces over the first day or two to balance the water, then add 10 ounces all at once the next time you refill your spa.)

Special Note:

It is extremely important that you check and re-tighten your pump couplers several times during the initial weeks of ownership of your new Float Pod. We have done this during the delivery process; but, the couplers may need to be re-tightened after the initial fill and warm up of the water.

Additionally, You should check the couplers often to insure they stay tight. If you have any questions please call your local dealer or 1-800-541-1248.

FLOAT POD CHEMISTRY

THINGS TO REMEMBER:

- Clean your **Filter** regularly. (Every 4-6 weeks) Clean your filter by spraying off with your garden hose or under the shower. Cleaning your filter with **Spray and Rinse** will help eliminate oil and grime. You may rotate two filters exchanging the dirty filter with a clean one. If a garden hose is not available, you can run your filter through the dishwasher (DO NOT USE SOAP OR DRY BY HEAT). It is recommended that you clean your filter after the first week of operation.
- Clean your **Skimmer Basket** regularly. (Every 1-2 weeks) Unscrew the basket, pull it out and remove any foreign debris. It is good practice to turn off your Float Pod before removing your Skimmer Basket. (See Page 15)
- It is recommended to rinse all floaters before a Float Session to remove unwanted body oil or lotions.
- Tighten the **Pump Couplers** in the equipment area. They can loosen over time from vibration causing a small drip near the pump. Hand tighten only. Loose couplers are not covered under warranty. (See Page 14)
- Bleed the excess air from the filter **Bleeder Valve** after cleaning the filter or changing the water. (See Page 15)
- **Filling the Float Pod** from inside the Filter Housing or from inside the Skimmer Basket opening can help prevent an air-lock in the Circulating Pump. Keep your **pH & Alkalinity** levels of the water in the proper range to avoid damage to the spa's components. Improper levels may cause damage to the spa that is not covered by your warranty. If your pH and Alkalinity level are high, add pH/Alkalinity-Down. This will lower the levels at the same time. If your pH level and Alkalinity level are low, add pH/Alkalinity-Up. This will raise the levels at the same time. It is very important to keep levels up, if the pH is low for a long period of time the water becomes acidic and will corrode the components on your Float Pod. It is important to keep both the pH and Alkalinity levels balanced because they help to hold each other within desired limits. Proper pH and Alkalinity levels help other chemicals used in your Float Pod to be more effective.
- **High Bromine and High Chlorine** levels may cause damage to the Float Pod that is not covered by your warranty. Contact your authorized Royal Spa Representative for instructions on lowering high levels of Bromine or Chlorine. It may not be necessary to put Bromine or Chlorine into your Float Pod every week depending on use.

Float Pod Mechanical

Equipment Identification

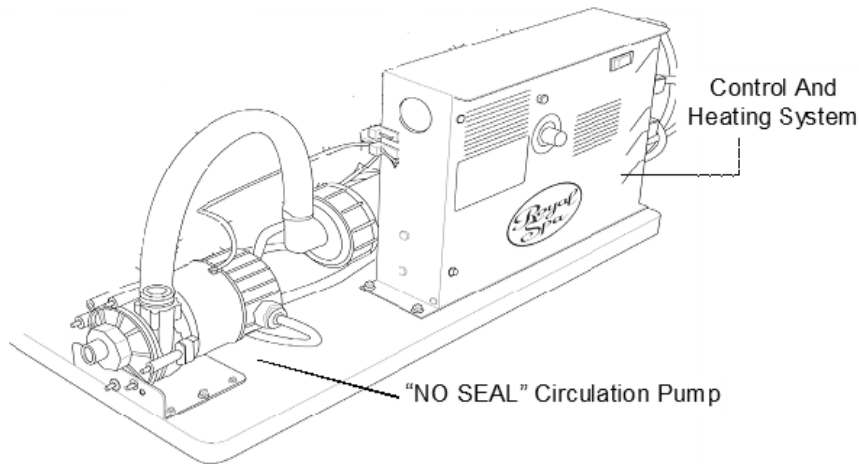

Command Center:

The Float Pod comes with our Command Center controller. This houses a digital temperature reader and can be set to 1/10th of a degree. For Commercial Float Pods different lobby controls will controls different Pod features. The Thermostat control is designed for ease of use and maximum durability. Simply push the Thermostat up/down to the approximate location of the desired temperature and adjust accordingly for the fine tuning.

Indicator Lights:

- READY = Indicates the spa water temperature is at or above the thermostat 's set position.
- HEAT = Indicates the spa water temperature is below the thermostat 's set position and the heater is "ON" to bring the temperature up.

Commercial Sanitation:

Ultra Pure Ozone Generator and Trident UV are built into Commercial Float Pods.



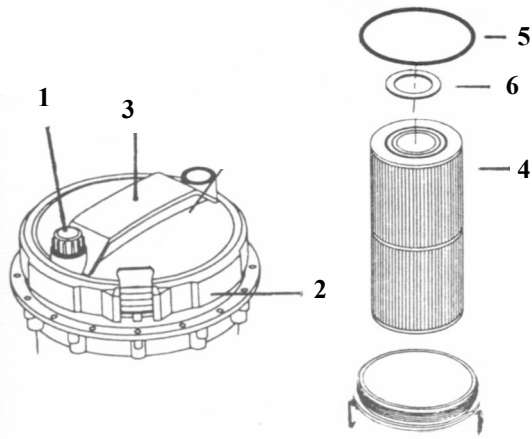

REMOVING YOUR FILTER (with power off)

- Bleed air from filter housing and turn knob (1) counter-clockwise.
- Rotate filter ring (2) counter-clockwise and remove.
- Pull up on filter lid handle (3) and remove (4) filter to clean or replace. Check O ring (5) for damage.

REPLACING YOUR FILTER (with power off)

Replace ring (6), and reverse above steps turning filter ring (2) clockwise until hand tight. Turn power on - when water comes out of bleed knob (1), close, turning clockwise hand tight.



Float Pod Surface Skimmer: This device is located at the water level of the Float Pod. It pulls debris from the surface, pre-filters the water through the “Skimmer Basket”, and then pumps the water through the fiber filter. The Skimmer Basket should be cleaned about once every two (2) to four (4) weeks. The basket is removed for cleaning by un-threading the Skimmer Retainer and removing the basket.

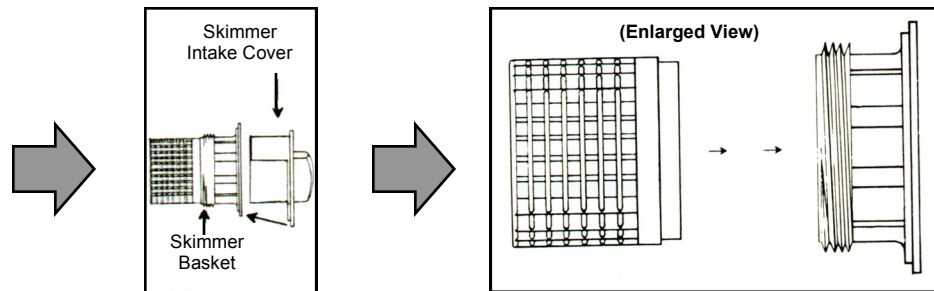

DRAINING YOUR POD

Draining your pod is an easy procedure. Place one end of your garden hose in a drain or in your yard, and place the other end against a water jet. Turn on the jets and let it push water through the hose until it produces a stream out of the hose. At this point, put the jet end of the hose in the bottom of the foot-well of your pod, and it will siphon the water down to that point. **Be sure to turn off the jets and power** after putting the hose in the foot-well.

CAUTION

Epsom Salt Drain Requirements

CAUTION

It is NOT recommended to flush 1,200lbs of Epsom Salt into a septic tank or septic system. This could disrupt localized bacteria production. Please consult with a septic system expert for more information. You may be required to drain into storage tanks should you need to drain your Float Pod.

Check with City officials about Epsom Salt into City Sewer. Royal Spa takes no responsibility for damage to septic or sewer systems.

FLOAT POD CHEMISTRY 101

Water Quality Maintenance

Maintaining the quality of the water within specified limits will enhance your enjoyment and prolong the life of the spa's equipment system and other spa components. It is a fairly simple task, but it requires regular attention because the water chemistry involved is a balance of several factors. There is no simple formula, and there is no avoiding it. A careless attitude in regard to water maintenance will result in poor and potentially unhealthful conditions for soaking and even damage to your spa. For specific guidance on maintaining water quality, consult your authorized Royal Spa Dealer who can recommend the appropriate chemical products for sanitizing and maintaining your Float Pod.

Sanitizing

To destroy bacteria and organic compounds in the pod water, a sanitizer must be used regularly. Chlorine and Bromine are the two most popular sanitizers used. Shock Out is another sanitizer used that also enhances the effectiveness of Bromine and Chlorine. Many other additives are available for your pod. Some are necessary to compensate for out-of-balance water (pH/Alk Up & pH/Alk Down), some aid in cosmetic water treatment (Spa Brite & Foam Gone) and others simply alter the feel or smell of the water (Scum Out). Your authorized Royal Spa Dealer can advise you on the use of these additives.

Ozone Water Purifier

Float Pods equipped with an Ozone Purifier have drastically better overall water quality. You will find that your water stays fresh and clear with significantly fewer chemicals. You will also likely be able to go longer between complete pod water changes. Most pod testing equipment recommends keeping the bromine level around 3-6 ppm. You will likely not need a level that high with a properly functioning Ozone Purifier.

SPA CHEMICALS

- pH/Alkalinity Down** Lowers the pH of the spa water (active ingredients, sodium Bisulfate 100%).
- pH/Alkalinity Up** Raises pH, (active ingredient sodium carbonate)& Raises total alkalinity of spa water- initial component of water balance prevents pH bounce and deterioration of spa surfaces, fittings from alkalinity.
- Granulated Chlorine** A concentrated compound prepared to destroy and control the growth of bacteria and algae in spas. Aids in spa water clarity.

AVAILABLE ONLINE AT:
www.royalspa.com

Notes:

**Royal Spa Manufacturing
2041 West Epler Avenue
Indianapolis, IN 46217**

Phone: (317) 781-0828

Fax: (317) 781-1115

Watts: (800) 541-1248